

# Newco<sup>®</sup>

**Forged Steel Bolted & Welded Bonnet Gate Valves**

*Manufactured by Newmans™*

**Sizes: 1/4" thru 3" • Pressure Class: 150 thru 4500**



## Typical Newco Forged Steel Bolted & Welded Bonnet Gate Valve Expanded View

**1. Handwheel Nut:** The handwheel nut secures the handwheel to the bonnet assembly.

**2. Handwheel:** The handwheel cycles the valve.

**3. Stem Nut:** The stem nut provides a precision guide for proper stem alignment.

**4. & 11. Gland Bolts & Nuts:** The gland bolt and nut allows for easy adjustments for packing compression.

**5. Stuffing Box:** The stuffing box contains the packing.

**6. Bonnet Bolts:** The bonnet bolts secure the bonnet to the body.

**7. Yoke & Bonnet:** Newco bonnet assemblies are built to the same standards as the bodies. Larger size gate valves utilize a multi-piece bonnet design.

**8. Bonnet Gasket:** The bonnet gasket creates a leakproof seal between the bonnet and body.

**9. Body:** Newco forged steel bodies provide low resistance flow and optimum strength and performance.

**10. Seat Rings:** To ensure a stable shutoff, seat rings are aligned and swaged into the valve, then precision ground for optimal seating.

**12. Gland Flange:** Applies pressure to the gland for accurate packing adjustments.

**13. Gland:** Compresses the packing to create a stem seal above the back seat, between the bonnet and stem.

**14. Packing:** The packing creates a seal above the back seat, between the bonnet and stem.

**15. Stem:** The stem is precision machined and inserts into the horizontal channel in the disc.

**16. Wedge:** Newmans solid wedge is machined to the tightest tolerances to ensure trouble free shutoff and cycling.

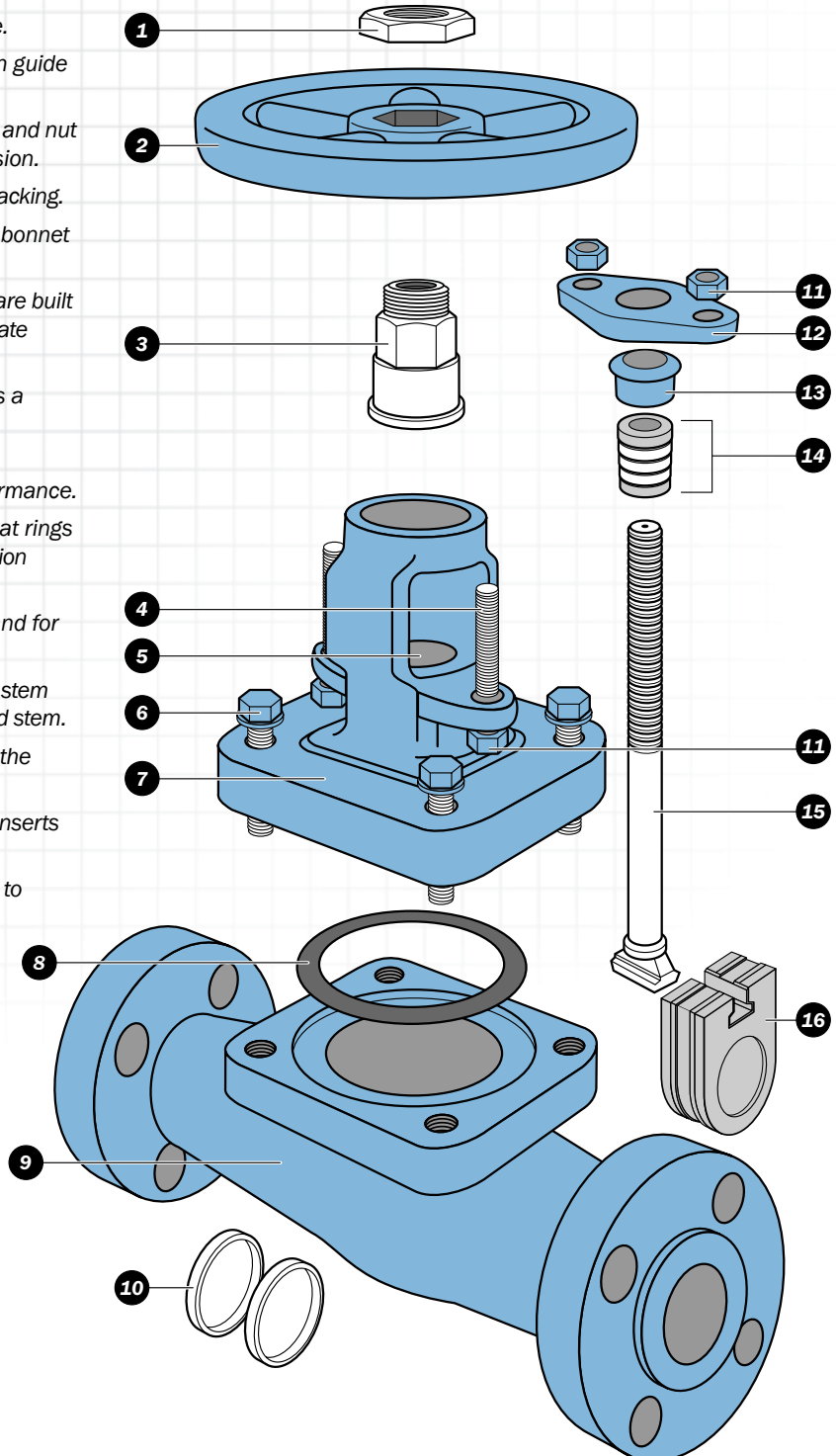

## Forged Steel Bolted & Welded Bonnet Gates Threaded, Socket Weld & Buttweld Ends Conventional Port Class 800 thru 2500 Sizes: 1/4" thru 3"

### Design and Manufacturing Standards

Valve Design: API 602
Pipe Threads, General Purpose, Inch: ASME B1.20.1
Socket Welding & Threaded: ASME B16.11
Tested in Accordance with: API 598
Recommended Spare Parts*

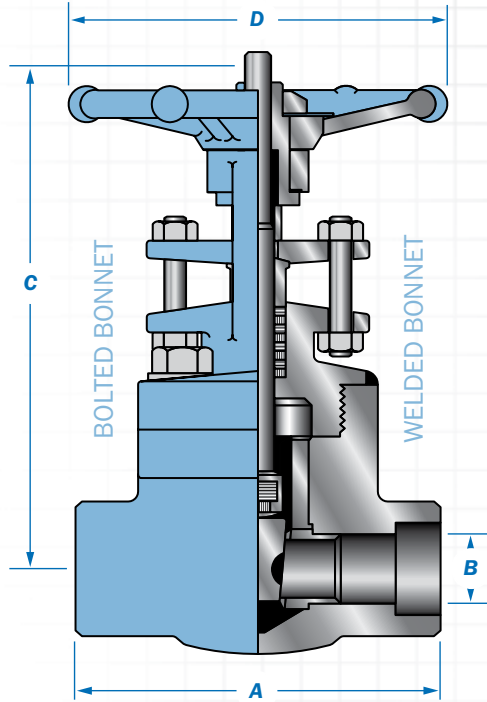

### Class 800 thru 2500 Bolted & Welded Bonnet Gates

Size in. mm	Class 800 WB					Class 800 BB				
	A	B	C	D	Wt.	A	B	C	D	Wt.
1/4	3.1	0.31	5.7	3.1	3.5	3.1	0.31	5.7	3.1	3.9
6	80	8	145	80	1.6	80	8	145	80	1.8
3/8	3.1	0.39	5.7	3.1	3.5	3.1	0.39	5.7	3.1	3.9
9	80	10	145	80	1.6	80	10	145	80	1.8
1/2	3.2	0.39	5.7	3.2	3.1	3.2	0.39	5.7	3.2	3.1
15	80	10	145	80	1.6	80	10	145	80	1.8
3/4	3.5	0.55	6.1	3.2	3.4	3.5	0.55	6.1	3.2	3.7
20	90	14	155	80	1.7	90	14	155	80	1.9
1	4.3	0.71	7.3	3.9	4.7	4.3	0.71	7.3	3.9	5.6
25	110	18	185	100	3.2	110	18	185	100	3.6
1-1/4	5.0	0.95	8.6	4.7	5.9	5.0	0.95	8.6	4.7	8.1
32	127	24	218	120	4.8	127	24	218	120	5.3
1-1/2	5.0	1.22	10.0	5.5	14.3	5.0	1.22	10.0	5.5	15.4
40	127	30	255	140	6.5	127	30	255	140	7.5
2	5.1	1.44	10.9	5.5	18.7	5.1	1.44	10.9	5.5	20.0
50	130	36.5	277	140	8.5	130	36.5	277	140	9.8
3	-	-	-	-	-	7.3	2.13	15.5	11.3	56
75	-	-	-	-	-	184.2	53.98	393.7	285.8	25.5
Size in. mm	Class 1500 WB					Class 1500 BB				
	A	B	C	D	Wt.	A	B	C	D	Wt.
1/2	3.5	0.39	6.07	3.2	4.9	3.5	0.39	6.07	3.2	4.9
15	90	10	152	80	2.2	90	10	152	80	2.5
3/4	4.3	0.55	7.1	3.9	4.9	4.3	0.55	7.1	3.9	5.6
20	110	14	180	100	3.6	110	14	180	100	4.3
1	4.7	0.75	8.6	4.7	6.2	4.7	0.75	8.6	4.7	8.5
25	120	18	218	120	5.2	120	18	218	120	6.1
1-1/4	5.1	0.95	9.8	5.5	6.2	5.1	0.95	9.8	5.5	8.6
32	130	24	250	140	7.5	130	24	252	140	8.7
1-1/2	5.1	1.16	10.8	5.5	22.0	5.1	1.16	10.8	5.5	22.4
40	130	29	275	140	17.8	130	29	289.5	170	17.8
2	5.9	1.44	12.6	6.7	33.0	5.9	1.44	12.6	6.7	33.0
50	150	36.5	320	170	20.7	150	37	365.7	170	20.7
Size in. mm	Class 2500 WB					Class 2500 BB				
	A	B	C	D	Wt.	A	B	C	D	Wt.
1/2	4.3	0.39	6.9	3.9	6.3	4.3	0.39	6.9	3.9	6.3
15	110	10	175	100	3.5	110	10	175	100	4.0
3/4	4.7	0.55	8.3	4.7	6.3	4.7	0.55	8.3	4.7	7.1
20	120	14	210	120	5.5	120	14	210	120	6.5
1	5.1	0.75	9.4	5.5	7.1	5.1	0.75	9.4	5.5	10.4
25	130	18	240	140	7.5	130	18	240	140	8.5
1-1/4	5.1	0.95	11.0	6.7	7.8	5.1	0.95	11.0	6.7	10.4
32	130	24	280	170	10.9	130	24	280	170	12.1
1-1/2	5.1	1.16	12.2	6.7	35.2	5.1	1.16	12.2	6.7	35.2
40	210	29	310	170	19.8	210	29	310	170	19.8
2	9.4	1.44	14	10.2	11.8	9.4	1.44	14	10.2	11.8
50	240	36.5	355	260	29.7	240	36.5	355	260	29.7

### Typical Bill of Materials (See page 12 for available materials.)

Component	Material	ASTM Spec	Component	Material	ASTM Spec
Body	Carbon Steel	A105N	Handwheel Nut	Carbon Steel	Commercial
Bonnet	Carbon Steel	A105N	Nameplate	Aluminum	Commercial
* Packing	Graphite W/Braided Carbon Fiber End Rings		Handwheel	Carbon Steel	A105N
* Gasket	Stainless Steel 316 Graphite		Yoke Sleeve	Stainless Steel	AISI 416
Stem	Stainless Steel	A479-410	Gland Nuts	Carbon Steel	A194 2H
Wedge	Stainless Steel	13 Chrome	Gland Flange	Carbon Steel	A105N
Seat Rings	Stainless Steel	A479-410	Gland Studs	Stainless Steel	AISI 410
Bonnet Bolt	Alloy Steel	A193 B7	Packing Gland	Stainless Steel	A479-316

Note: Dimensions: Inches/Millimeters - Weights: Pounds/Kilograms. Dimensions are subject to change without notice.

**Forged Steel Extended Body Gates**  
**Bolted & Welded Bonnet**  
**Conventional Port**  
**Class 800 thru 1500**  
**Sizes: 1/2" thru 2"**

**Design and Manufacturing Standards**

Valve Design: API 602
Pipe Threads, General Purpose, Inch: ASME B1.20.1
Socket Welding : ASME B16.11
Tested in Accordance with: API 598
Recommended Spare Parts*

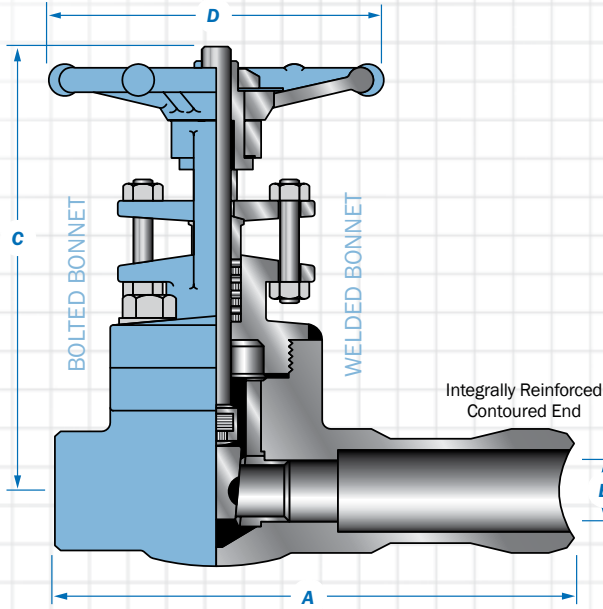

**Available Ends**

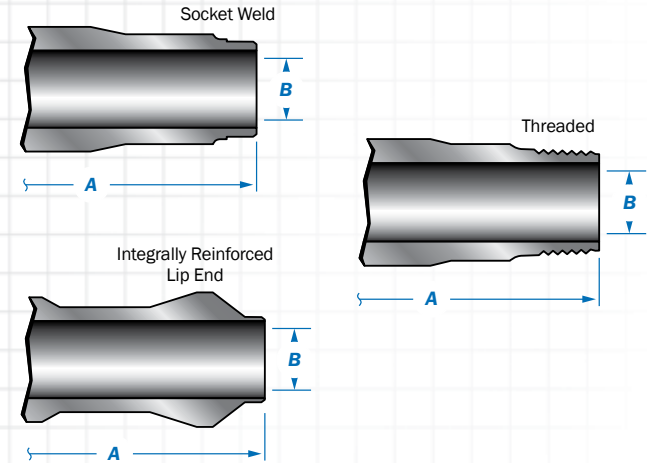

**Class 800 & 1500 Extended Body - Bolted & Welded Bonnet Gate**

Size in. mm	Class 800 IR Contoured End					Class 800 IR - Lip End					Class 800 Threaded					Class 800 Socket Weld														
	A		B		C		D		Wt.		A		B		C		D		Wt.		A		B		C		D		Wt.	
	41	45	41	45	41	45	41	45	41	45	41	45	41	45	41	45	41	45	41	45	41	45	41	45	41	45	41	45	41	45
1/2	8.6	0.39	5.9	3.2	6	8.6	0.39	5.9	3.2	6	5.6	0.39	6.4	3.1	5.7	5.6	0.39	6.4	3.1	5.7	5.6	0.39	6.4	3.1	5.7	5.6	0.39	6.4	3.1	
15	207	9.9	150	81	3	207	9.9	150	81	3	141.5	10	162	80	2.6	141.5	10	162	80	2.6	141.5	10	162	80	2.6	141.5	10	162	80	
3/4	8.6	0.55	6.1	3.2	7	8.6	0.55	6.1	3.2	7	5.8	0.55	7.3	3.9	6.4	5.8	0.55	7.3	3.9	6.4	5.8	0.55	7.3	3.9	6.4	5.8	0.55	7.3	3.9	
20	218	13.9	155	81	3	218	13.9	155	81	3	146.5	14	185	100	2.9	146.5	14	185	100	2.9	146.5	14	185	100	2.9	146.5	14	185	100	
1	9.6	0.71	7.3	3.9	10	9.6	0.71	7.3	3.9	10	6.5	0.7	7.6	3.9	9.5	6.5	0.7	7.6	3.9	9.5	6.5	0.7	7.6	3.9	9.5	6.5	0.7	7.6	3.9	
25	245	18	185	99	5	245	18	185	99	5	166	18	192	100	4.3	166	18	192	100	4.3	166	18	192	100	4.3	166	18	192	100	
1-1/2	10.4	1.14	10.2	5.5	19	10.4	1.14	10.2	5.5	19	7.5	1.14	10	5.5	19.4	7.5	1.14	10	5.5	19.4	7.5	1.14	10	5.5	19.4	7.5	1.14	10	5.5	
40	263	28.9	259	140	9	263	28.9	259	140	9	191	29	255	140	8.8	191	29	255	140	8.8	191	29	255	140	8.8	191	29	255	140	
2	11.4	1.44	10.8	5.5	29	11.4	1.44	10.8	5.5	29	8.5	1.44	10.7	6.7	28.6	8.5	1.44	10.7	6.7	28.6	8.5	1.44	10.7	6.7	28.6	8.5	1.44	10.7	6.7	
50	289	36.6	274	140	13	289	36.6	274	140	13	216	36.5	273	170	13	216	36.5	273	170	13	216	36.5	273	170	13	216	36.5	273	170	
Size in. mm	Class 1500 Re-Out-Forced					Class 1500 Re-In Forced					Class 1500 Threaded					Class 1500 Socket Weld														
	A		B		C		D		Wt.		A		B		C		D		Wt.		A		B		C		D		Wt.	
	41	45	41	45	41	45	41	45	41	45	41	45	41	45	41	45	41	45	41	45	41	45	41	45	41	45	41	45	41	45
1/2	8.6	0.39	5.4	3.2	6	8.6	0.39	5.4	3.2	6	5.7	0.39	6.5	3.2	6.4	5.7	0.39	6.5	3.2	6.4	5.7	0.39	6.5	3.2	6.4	5.7	0.39	6.5	3.2	
15	218	9.9	138	80	3	218	9.9	138	80	3	146	10	165	80	2.9	146	10	165	80	2.9	146	10	165	80	2.9	146	10	165	80	
3/4	9.6	0.55	6.3	3.9	10	9.6	0.55	6.3	3.9	10	6.5	0.55	7.1	3.9	9.5	6.5	0.55	7.1	3.9	9.5	6.5	0.55	7.1	3.9	9.5	6.5	0.55	7.1	3.9	
20	245	13.9	161	100	5	245	13.9	161	100	5	166	14	180	100	4.3	166	14	180	100	4.3	166	14	180	100	4.3	166	14	180	100	
1	10.4	0.75	8.6	4.7	15	10.4	0.75	8.6	4.7	15	7.5	0.7	9.4	5.5	19.4	7.5	0.7	9.4	5.5	19.4	7.5	0.7	9.4	5.5	19.4	7.5	0.7	9.4	5.5	
25	264	19	218	120	7	264	19	218	120	7	191	18	240	140	8.8	191	18	240	140	8.8	191	18	240	140	8.8	191	18	240	140	
1-1/2	10.5	1.16	9.4	5.5	25	10.5	1.16	9.4	5.5	25	8.5	1.14	10.6	6.7	29.7	8.5	1.14	10.6	6.7	29.7	8.5	1.14	10.6	6.7	29.7	8.5	1.14	10.6	6.7	
40	267	29.5	238	140	11	267	29.5	238	140	11	216	29	270	170	13.5	216	29	270	170	13.5	216	29	270	170	13.5	216	29	270	170	
2	12.8	1.44	10.9	6.7	35	12.8	1.44	10.9	6.7	35	9.8	1.44	12.6	10.2	41.1	9.8	1.44	12.6	10.2	41.1	9.8	1.44	12.6	10.2	41.1	9.8	1.44	12.6	10.2	
50	325	36.6	276	170	16	325	36.6	276	170	16	250	36.5	320	260	18.7	250	36.5	320	260	18.7	250	36.5	320	260	18.7	250	36.5	320	260	

**Typical Bill of Materials** (See page 12 for available materials.)

Component	Material	ASTM Spec	Component	Material	ASTM Spec
Body	Carbon Steel	A105N	Handwheel Nut	Carbon Steel	Commercial
Bonnet	Carbon Steel	A105N	Nameplate	Aluminum	Commercial
* Packing	Graphite W/Braided Carbon Fiber End Rings		Handwheel	Carbon Steel	A105N
* Gasket	Stainless Steel 316 Graphite		Yoke Sleeve	Stainless Steel	AISI 416
Stem	Stainless Steel	A479-410	Gland Nuts	Carbon Steel	A194 2H
Wedge	Stainless Steel	13 Chrome	Gland Flange	Carbon Steel	A105N
Seat Rings	Stainless Steel	A479-410	Gland Studs	Stainless Steel	AISI 410
Bonnet Bolt	Alloy Steel	A193 B7	Packing Gland	Stainless Steel	A479-316

Note: Dimensions: Inches/Millimeters - Weights: Pounds/Kilograms. Dimensions are subject to change without notice.



**Forged Steel Flanged End Gates  
Bolted & Welded Bonnet  
Conventional Port  
Class 150 thru 1500  
Sizes: 1/2" thru 2" (1/4" & 3/8" available upon request)**

**Design and Manufacturing Standards**

<b>Valve Design:</b> API 602
<b>Flange Dimensions:</b> ASME B16.5
<b>Face-to-Face Dimensions:</b> ASME B16.10
<b>Tested in Accordance with:</b> API 598
<b>Recommended Spare Parts*</b>

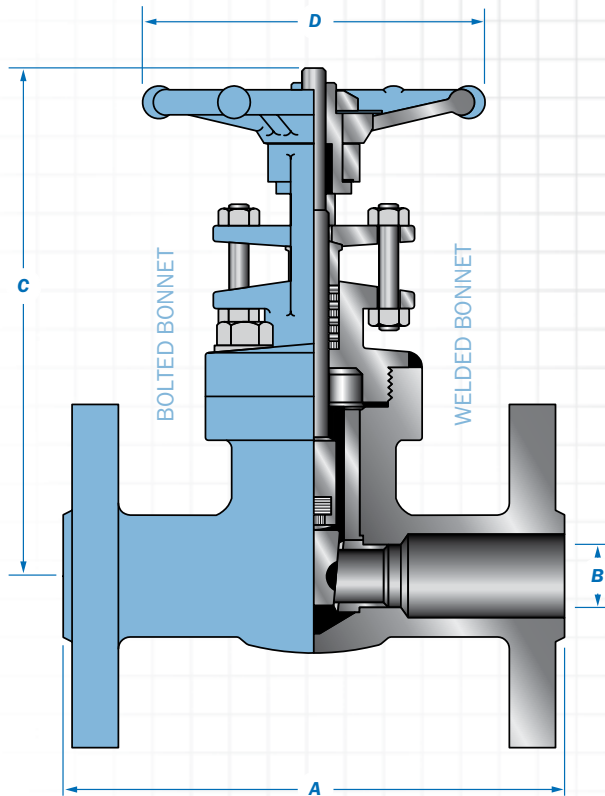

**Class 150 thru 1500  
Bolted & Welded Bonnet Flanged Gates**

Size in. mm	Class 150 BB & WB									
	A		B		C		D		Wt.	
	41	45	41	45	41	45	41	45	41	45
1/2	4.3	0.39	0.39	6.8	4.9	3.2	6.8	6.6		
15	108	10	10	173	125	80	3.1	3		
3/4	4.6	0.55	0.55	7.1	5.2	3.2	8.6	7.7		
20	118	14	14	180	132	80	4	3.5		
1	5.0	0.71	0.71	8.1	6.7	4.0	12.1	12.1		
25	127	18	18	205	170	100	5.7	5.5		
1-1/4	5.5	0.94	0.95	9.3	7.6	4.8	18.1	15		
32	140	24	24	235	193	120	8.2	6.8		
1-1/2	6.5	1.22	1.14	10.2	8.3	5.5	23.4	22.9		
40	165	30	29	260	211	140	10.5	10.4		
2	7.0	1.44	1.44	11.7	9.3	5.5	32.0	31.7		
50	178	37	37	296	236	170	15.4	14.4		

Size in. mm	Class 300 BB & WB									
	A		B		C		D		Wt.	
	41	45	41	45	41	45	41	45	41	45
1/2	5.5	0.39	0.39	6.9	4.9	3.2	7.3	7.9		
15	140	10	10	174	125	80	4	3.6		
3/4	6.0	0.55	0.55	7.1	5.2	3.2	10.8	10.8		
20	153	14	14	180	132	80	5.4	4.9		
1	6.5	0.71	0.71	8.1	6.7	3.9	14.7	15.4		
25	165	18	18	205	170	100	6.5	7		
1-1/4	7.0	0.94	0.95	10.2	7.6	4.7	21.1	20.7		
32	178	24	24	260	193	140	12.5	9.4		
1-1/2	7.5	1.22	1.14	10.4	8.3	5.5	29.5	29.3		
40	191	30	29	265	211	140	13	13.3		
2	8.5	1.44	1.44	11.7	9.3	6.7	35.9	39.6		
50	216	37	37	296	236	170	17.5	18		

Size in. mm	Class 600 BB & WB									
	A		B		C		D		Wt.	
	41	45	41	45	41	45	41	45	41	45
1/2	6.5	0.39	0.39	5.7	4.9	3.2	7.7	9.2		
15	165	10	10	145	125	80	4.2	4.2		
3/4	7.5	0.55	0.55	6.1	5.2	3.2	11.7	12.8		
20	191	14	14	155	132	80	5.6	5.8		
1	8.5	0.71	0.71	7.3	6.7	4.0	15.7	19.4		
25	216	18	18	185	170	100	7.2	8.8		
1-1/4	9.0	1.14	0.95	9.8	7.6	5.5	30.9	26.6		
32	229	29	24	248	193	140	14.5	12.1		
1-1/2	9.5	1.22	1.14	9.8	8.3	5.5	30.9	34.3		
40	241	30	29	248	211	140	14.5	15.6		
2	11.5	1.44	1.44	10.7	9.3	5.6	40.8	34.3		
50	292	37	37	273	236	170	18	19.5		

Size in. mm	Class 1500 BB & WB									
	A		B		C		D		Wt.	
	41	45	41	45	41	45	41	45	41	45
1/2	8.5	0.55	0.55	8.3	7.8	3.9	22	9		
15	216	14	14	210	198	100	10	4		
3/4	9	0.71	0.55	10.0	7.8	4.7	33	9.5		
20	229	18	14	255	198	120	15	4.3		
1	10	0.94	0.71	10.8	8.6	5.5	37.4	13.5		
25	254	24	18	275	218	140	17	6		
1-1/4	-	-	0.95	-	9.3	-	-	19.2		
32	-	-	24	-	236	-	-	8.7		
1-1/2	12	1.44	1.14	15	10.8	6.8	77	26.9		
40	305	36.5	29	380	274	172	35	12		
2	14.5	1.57	1.44	15.3	12.6	10.2	121	39		
50	368	40	37	388	320	260	55	17.7		

**Typical Bill of Materials** (See page 12 for available materials.)

Component	Material	ASTM Spec
Body	Carbon Steel	A105N
Bonnet	Carbon Steel	A105N
* Packing	Graphite W/Braided Carbon Fiber End Rings	
* Gasket	Stainless Steel 316 Graphite	
Stem	Stainless Steel	A479-410
Wedge	Stainless Steel	13 Chrome
Seat Rings	Stainless Steel	A479-410
Bonnet Bolt	Alloy Steel	A193 B7
Handwheel Nut	Carbon Steel	Commercial
Nameplate	Aluminum	Commercial
Handwheel	Carbon Steel	A105N
Yoke Sleeve	Stainless Steel	AISI 416
Gland Nuts	Carbon Steel	A194 2H
Gland Flange	Carbon Steel	A105N
Gland Studs	Stainless Steel	AISI 410
Packing Gland	Stainless Steel	A479-316

Note: Dimensions: Inches/Millimeters - Weights: Pounds/Kilograms. Larger sizes available on request. Dimensions are subject to change without notice.

**Forged Steel High Pressure  
Welded Bonnet Gate  
Conventional Port  
Class 4500  
Sizes: 1/2" thru 2"**

**Design and Manufacturing Standards**

<b>Valve Design:</b> ASME B16.34
<b>Pipe Threads, General Purpose, Inch:</b> ASME B1.20.1
<b>Socket Welding:</b> ASME B16.11
<b>Tested in Accordance with:</b> API 598
<b>Recommended Spare Parts*</b>

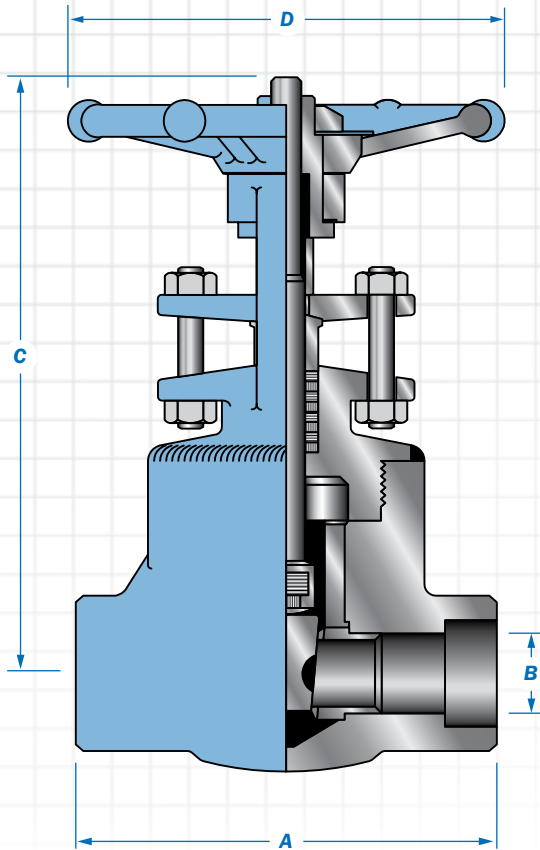

**Class 4500  
Welded Bonnet Gate**

Size	A	B	C	D	Wt.
1/2	4.7	0.47	10.4	5.5	17.6
15	120	12	265	140	8
3/4	5.1	0.47	10.4	5.5	19.8
20	130	12	265	140	9
1	5.1	0.47	10.4	6.7	19.8
25	130	12	265	170	9
1-1/4	8.3	0.63	12.4	6.7	31.9
32	210	16	315	170	14.5
1-1/2	8.3	0.63	12.4	10.2	33
40	210	16	315	260	15
2	9.4	0.83	15.4	10.2	41.8
50	240	21	390	260	19

**Typical Bill of Materials** (See page 12 for available materials.)

Component	Material	ASTM Spec
<b>Body</b>	Carbon Steel	A105N
<b>Bonnet</b>	Carbon Steel	A105N
<b>* Packing</b>	Graphite W/Braided Carbon Fiber End Rings	
<b>* Gasket</b>	Stainless Steel 316 Graphite	
<b>Stem</b>	Stainless Steel	A479-410
<b>Wedge</b>	Stainless Steel	13 Chrome
<b>Seat Rings</b>	Stainless Steel	A479-410
<b>Bonnet Bolt</b>	Alloy Steel	A193 B7
<b>Handwheel Nut</b>	Carbon Steel	Commercial
<b>Nameplate</b>	Aluminum	Commercial
<b>Handwheel</b>	Carbon Steel	A105N
<b>Yoke Sleeve</b>	Stainless Steel	AISI 416
<b>Gland Nuts</b>	Carbon Steel	A194 2H
<b>Gland Flange</b>	Carbon Steel	A105N
<b>Gland Studs</b>	Stainless Steel	AISI 410
<b>Packing Gland</b>	Stainless Steel	A479-316

**Note:** Dimensions: Inches/Millimeters - Weights: Pounds/Kilograms. Larger sizes available on request. Dimensions are subject to change without notice.