

CRANE

Distributed by: www.collinspipe.com

THE
COLLINS
COMPANIES

NEW!

Crane® FKX 9000 Triple Offset Butterfly Valves

CraneFKX9000.com



Key features include:

1 Optimized Seat Angle: An innovative seat angle design and Stellite® hard-faced valve body seat deliver a longer seal life and improved abrasion resistance, even after extensive cycling. Designed to eliminate wedging or binding of the disc, and lower the operating torque, the Crane®FKX 9000 can **REDUCE TOTAL COST OF OWNERSHIP BY UP TO 50%.***

**Tested in MDI application*

2 Metal-to-Metal Sealing: The precision machined metal seat and seal ring deliver reliable and bi-directional shutoff in high-temperature, high-pressure and severe service applications among others. The right-angle conical design facilitates an almost **FRICTION-LESS IN-LINE SEALING.**

3 Innovative Stem Seal Design: permits superior FUGITIVE EMISSIONS CONTROL (ISO 15848, Class AH) under recurrent and extreme thermal cycling, and **REDUCES POTENTIAL DOWN TIME.**

4 Torque-Seating: Unlike position-seated ball, butterfly or plug valves, the torque-seated Crane®FKX 9000 self-adjusts to evenly distribute seal compression. A “floating” seal ring and wide seal ring supporting gasket yield a **BETTER SEAL** to eliminate binding and to enhance performance.

5 Innovative Shaft Design: unlike alternative designs, Crane®FKX 9000 delivers **SUPERIOR PERFORMANCE IN THERMAL EXPANSION** due to the optimal positioning of the pin connector, located in the lower portion of the disk. Our bearing design also helps to prevent shaft deflection and permits **LONGER VALVE LIFE.**

CRANE

www.cranecpe.com

Crane® FKX 9000 Triple Offset Butterfly Valves

Materials of Construction

- Standard: A216 Gr. WCB, A351 Gr. CF8M
- Special (upon request): Duplex, Superduplex, LCC/LCB, WC6, CF3M, Monel®, Inconel®, Hastelloy®, Alloy 20

Size Range

- 3" up to 24", in a single piece cast body

Pressure Ratings

- ASME Class 150#, Class 300#

Temperature Range

- -140°F up to 1022°F; -60°C up to 550°C
- Up to 1200°F (649°C) possible with stem extension

Body Configurations

- Lug, API 609 table 3
- Double Flanged, Short Pattern, API 609 table 3
- Double Flanged, Long Pattern, API 609 table 3



Compliance

- ASME B16.34 valve design standard
- Zero leakage* as per API 598 & API 6D
- API 607, 6th edition: Fire Tested
- EPA Method 21 (Fugitive Emissions Compliance)
- ISO 15848, Class AH (Fugitive Emissions Compliance)
- Quality certification as per ISO 9001

Typical Applications

- Steam Isolation
- Refining
- Chemical & Petrochemical Processing
- Power Generation
- Gas Processing
- Marine
- Paper & Pulp
- Hydrocarbon Storage & Transportation
- District Heating

Metal to Metal Sealing

- Metal-to-metal sealing between the seal ring and the body seat allows for high temperature, high pressure and severe service handling with zero-leakage* sealing performance
- The "right-angle conical" design facilitates an almost friction-less sealing

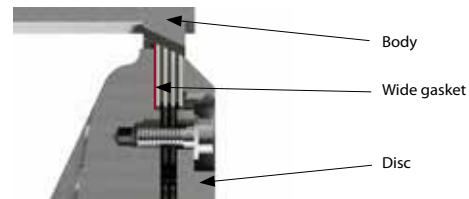

Special Options

- Low emissions stem packing option for <50 ppmv
- Monitoring and flushing ports for ease of maintenance by purging contaminants from the stung box
- Pressure tight bearing protector
- Graphite-free, full metal seal ring

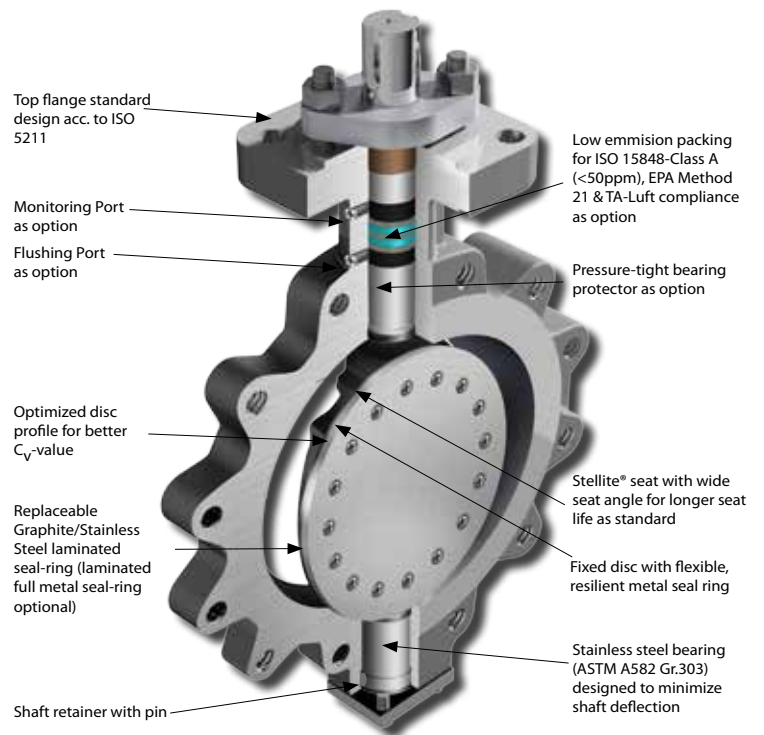

Crane ChemPharma & Energy