

# B<sup>®</sup> GATE VALVES- WELDED BONNET- FULL PORT

BONNEY FORGE

**2500 LB.**

**4500 LB.**

**Design construction:**

- ASME B16.34
- Outside Screw and Yoke (OS&Y)
- Self aligning two piece packing gland
- Integral backseat
- Body Bonnet Weld to ASME IX
- Socket Weld Ends to ASME B16.11
- Screwed Ends (NPT) to ASME B1.20.1
- Butt Welding Ends to ASME B16.25
- Ratings standard class:
- carbon steel class 2500 6170 psig @ 100°F  
425 bar + 38°C
- carbon steel class 4500 11100 psig @ 100°F  
765 bar + 38°C

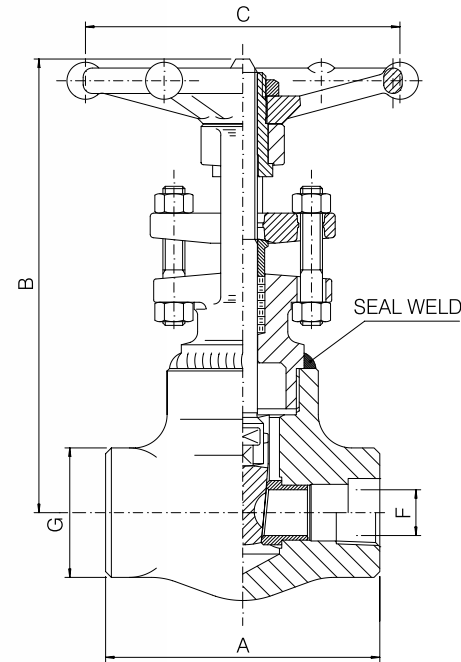

		FULL PORT – FIG. 25W 10									
SIZE	inch	1/4	3/8	1/2	3/4	1	1 1/4	1 1/2	2		
	mm	6	10	15	20	25	32	40	50		
A	inch	4.33	4.33	5	5	5	5	8.27	9.06		
	mm	110	110	127	127	127	127	210	230		
B open	inch	7.20	7.20	8.43	9.61	10.87	10.87	13.27	15.91		
	mm	183	183	214	244	276	276	337	404		
C	inch	3.82	3.82	5.43	5.43	5.43	5.43	6.77	9.21		
	mm	97	97	138	138	138	138	172	234		
F	inch	.31	.31	.45	.59	.77	.98	1.10	1.38		
	mm	8	8	11.5	15	19.5	25	28	35		
G	inch	1.89	1.89	2.20	2.52	3.07	3.07	3.35	3.74		
	mm	48	48	56	64	78	78	85	95		
Weight	lb.	11.25	11.5	11.75	15.75	21.5	21.5	43	63.75		
	kg	5.2	5.3	5.4	7.2	9.8	9.8	19.5	29		
PACKING		2B4	2B4	2B4	BH8	BH8	2B5	2B5	2B8		

		FULL PORT – FIG. 45W 10				
SIZE	inch	1/2	3/4	1	1 1/2	2
	mm	15	20	25	40	50
A	inch	5	5	9.06	9.06	17.76
	mm	127	127	230	230	451
B open	inch	10.39	10.83	14.37	15.75	17.56
	mm	264	275	365	400	446
C	inch	5.43	6.61	9.21	12.60	12.60
	mm	138	168	234	320	320
F	inch	.30	.45	.59	1.02	1.02
	mm	7.5	11.5	15	26	26
G	inch	3.07	3.07	3.74	3.74	4.72
	mm	78	78	95	95	120
Weight	lb.	22	26.5	40.8	59.5	81.5
	kg	10	12	18.5	27	37
PACKING		2B3	BH6	BY7	2B8	4B8

Available with Socket Weld or Butt-Weld Ends Only.  
Materials and trim specifications Page 91

- Overview .....16
- Bolted Bonnet- 800 lb. & 1500 lb. valves .....17
- Bolted Bonnet- 1500 lb. & 2500 lb. valves .....18
- Welded Bonnet- 800 lb. & 1500 lb. valves .....19
- Welded Bonnet- 2500 lb. & 4500 lb. valves .....20
- Welded Bonnet (Y type)- 800 lb. & 1690 lb. valves .....21
- Welded Bonnet (Y type)- 2680 lb. & 4500 lb. valves .....22

## GLOBE VALVES



## GLOBE VALVES

Forged steel, outside screw and yoke (OS&Y), rotating rising stem, rising handwheel. Full or standard port. Bolted or welded bonnet joint. T-Pattern or Y-Pattern. Integral back-seat. Integral body seat.

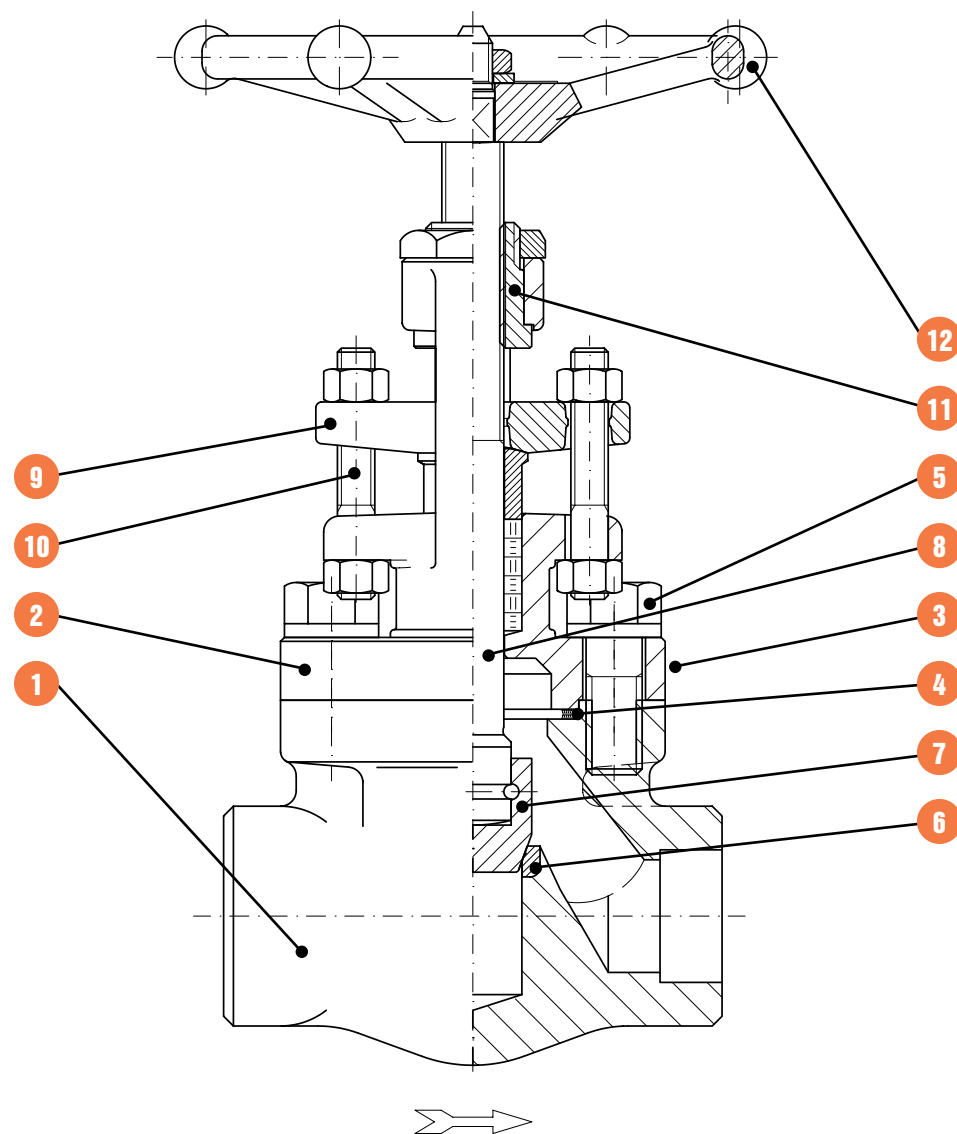

- BODY.** The body is forged steel and designed to the basic dimensional requirements of the applicable specifications such as API 602 and ASME B16.34. The body is available in both the full or standard port design. It is also available in either T-pattern or Y-pattern configuration.
- BONNET.** The bonnet is forged steel, has an integral backseat and incorporates the stuffing box, which has dimensions per the applicable specifications such as API 602.
- BODY-BONNET JOINT.** Two different bonnet joint designs are available. These are either the bolted bonnet or the threaded and seal welded type.
- GASKET.** The bolted bonnet joint design valve uses a contained, controlled compression, spiral wound type gasket.
- BONNET BOLTING.** The bonnet bolting is manufactured of alloy steel in accordance with the requirements of the applicable specifications such as API 602 and ASME B16.34.
- SEAT.** The body seat is an integral weld overlay and is part of the valve trim.
- DISC.** The disc is forged steel and is part of the valve trim. The disc seating surface is of the tapered or plug type design. The disc is attached to the stem using a loose or swivel disc arrangement.

- STEM.** The stem is forged steel and part of the valve trim. It contains an integral back seat shoulder, which mates with the integral backseat of the bonnet. The stem is designed to the basic dimensional requirements of the applicable specifications such as API 602.
- GLAND AND FLANGE.** The gland, gland flange assembly utilizes a separate, two piece design. This self aligning design allows the flange to be unevenly tightened while the gland maintains its parallel alignment with the stem and stuffing box.
- GLAND BOLTS AND NUTS.** The steel/stainless steel gland bolt and nut assembly is a stud, double nut arrangement. This design allows complete removal from the valve when service is required. The use of industry standard thread full length studs and nuts also allows easy replacement should these items be lost or in need of replacement.
- YOKE SLEEVE.** The yoke sleeve is of forged stainless steel material having a high melting point and is resistant to wear and corrosion.
- HANDWHEEL.** The handwheel is forged carbon steel of an open spoke design. This robust construction along with appropriate sizing allows for ease of operation.

**800 LB.**  
**1500 LB.**

**Design construction:**  
ASME B16.34 - BS 5352  
Testing according to API 598  
Marking MSS SP25  
Outside Screw and Yoke (OS&Y)  
Self aligning two piece packing gland  
Spiral-wound gasket  
Integral backseat  
Loose solid disc  
Socket Weld Ends to ASME B16.11  
Screwed Ends (NPT) to ASME B1.20.1  
Butt Welding Ends to ASME B16.25  
Ratings:  
- carbon steel class 800 1975 psig @ 100°F  
138 bar + 38°C  
- carbon steel class 1500 3705 psig @ 100°F  
255 bar + 38°C

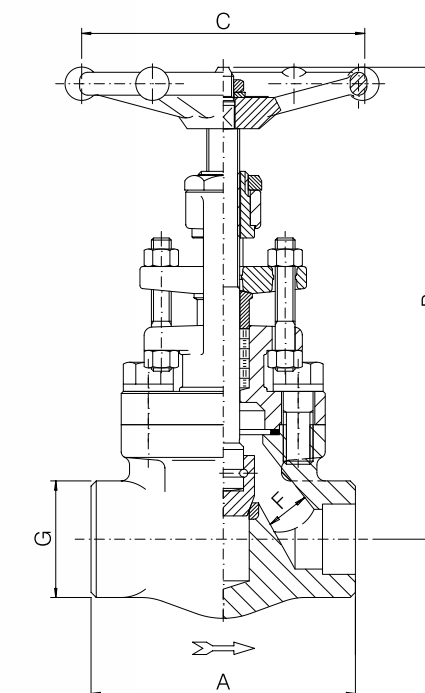

800 LB.		FULL PORT - FIG. H 30									
SIZE	inch mm	1/4 6	3/8 10	1/2 15	3/4 20	1 25	1 1/4 32	1 1/2 40	2 50		
A	inch mm	3.15 80	3.15 80	3.54 90	4.33 110	5 127	6 150	7.09 180	8.27 210		
B open	inch mm	6.54 166	6.54 166	6.73 171	8.39 213	9.72 247	10.16 258	11.81 300	14.76 375		
C	inch mm	3.46 88	3.46 88	3.46 88	3.82 97	5.43 138	5.43 138	6.77 172	6.77 172		
F	inch mm	.28 7	.35 9	.51 13	.69 17.5	.89 22.5	1.16 29.5	1.38 35	1.79 45.5		
G	inch mm	1.26 32	1.26 32	1.5 38	1.89 48	2.20 56	2.52 64	3.07 78	3.35 85		
Weight	lb. kg	4.75 2.2	4.75 2.2	5.25 2.4	8.25 3.8	13.25 6.1	16.75 7.6	27.5 12.5	43.25 19.6		
PACKING		BH3	BH3	BH3	BH5	BY5	BY5	BY7	BH8		
GASKET		G2	G2	G2	G3	G4	G6	G7	G9		

800 LB.		STANDARD PORT - FIG. HL 30					
SIZE	inch mm	1/2 15	3/4 20	1 25	1 1/2 40	2 50	
A	inch mm	3.15 80	3.54 90	4.33 110	6 150	7.09 180	
B open	inch mm	6.54 166	6.73 171	8.39 213	10.16 258	11.81 300	
C	inch mm	3.46 88	3.46 88	3.82 97	5.43 138	6.77 172	
F	inch mm	.35 9	.51 13	.69 17.5	1.16 29.5	1.38 35	
G	inch mm	1.26 32	1.5 38	1.89 48	2.52 64	3.07 78	
Weight	lb. kg	4.5 2.1	5 2.3	8 3.7	16.25 7.4	26.25 11.9	
PACKING		BH3	BH3	BH5	BY5	BY7	
GASKET		G2	G2	G3	G6	G7	

1500 LB.		FULL PORT - FIG. 9H 30									
SIZE	inch mm	1/4 6	3/8 10	1/2 15	3/4 20	1 25	1 1/4 32	1 1/2 40	2 50		
A	inch mm	3.54 90	3.54 90	4.33 110	5 127	6 150	7.09 180	8.27 210	9.06 230		
B open	inch mm	6.54 166	6.54 166	8.27 210	9.72 247	10.08 256	11.81 300	14.76 375	16.85 428		
C	inch mm	3.46 88	3.46 88	3.82 97	5.43 138	5.43 138	6.77 172	6.77 172	9.21 234		
F	inch mm	.28 7	.35 9	.47 12	.59 15	.79 20	1.06 27	1.26 32	1.57 40		
G	inch mm	1.5 38	1.5 38	1.89 48	2.20 56	2.52 64	3.07 78	3.35 85	3.74 95		
Weight	lb. kg	5.75 2.6	5.75 2.6	9.25 4.2	14.25 6.5	18.75 8.5	27.5 12.5	49 22.3	79.25 36		
PACKING		BH3	BH3	BH5	2B4	2B4	2B5	BH8	9B8		
GASKET		G1	G1	G2	G3	G4	G5	G7	G8		

1500 LB.		STANDARD PORT - FIG. 9HL 30					
SIZE	inch mm	1/2 15	3/4 20	1 25	1 1/2 40	2 50	
A	inch mm	3.54 90	4.33 110	5 127	7.09 180	8.27 210	
B open	inch mm	6.54 166	8.27 210	9.84 250	11.81 300	14.76 375	
C	inch mm	3.46 88	3.82 97	5.43 138	6.77 172	6.77 172	
F	inch mm	.35 9	.47 12	.59 15	1.06 27	1.26 32	
G	inch mm	1.5 38	1.89 48	2.20 56	3.07 78	3.35 85	
Weight	lb. kg	5.25 2.4	8.75 4	14.25 6.5	28.5 13	48.5 22	
PACKING		BH3	BH3	2B4	2B5	BH8	
GASKET		G1	G2	G3	G5	G7	

# B GLOBE VALVES- BOLTED BONNET- FULL PORT

BONNEY FORGE

**1500 LB.**

**2500 LB.**

**Design construction:**

- ASME B16.34 - BS 5352
- Testing according to API 598
- Marking MSS SP55
- Outside Screw and Yoke (OS&Y)
- Self aligning two piece packing gland
- Integral backseat
- Oval ring joint gasket
- Loose solid disc
- Socket Weld Ends to ASME B16.11
- Screwed Ends (NPT) to ASME B1.20.1
- Butt Welding Ends to ASME B16.25
- Ratings standard class:
  - carbon steel class 1500 3705 psig @ 100°F  
255 bar + 38°C
  - carbon steel class 2500 6170 psig @ 100°F  
425 bar + 38°C

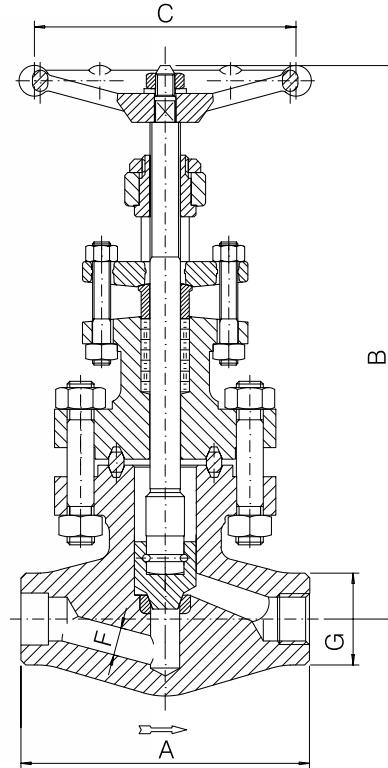

# B GLOBE VALVES- WELDED BONNET- FULL & STANDARD PORT

BONNEY FORGE

**800 LB.**

**1500 LB.**

**Design construction:**

- ASME B16.34 - BS 5352
- Testing according to API 598
- Marking MSS SP25
- Outside Screw and Yoke (OS&Y)
- Self aligning two piece packing gland
- Integral backseat
- Body bonnet weld to ASME IX
- Loose solid disc
- Socket Weld Ends to ASME B16.11
- Screwed Ends (NPT) to ASME B1.20.1
- Butt Welding Ends to ASME B16.25
- Ratings:
  - carbon steel class 800 1975 psig @ 100°F  
138 bar + 38°C
  - carbon steel class 1500 3705 psig @ 100°F  
255 bar + 38°C

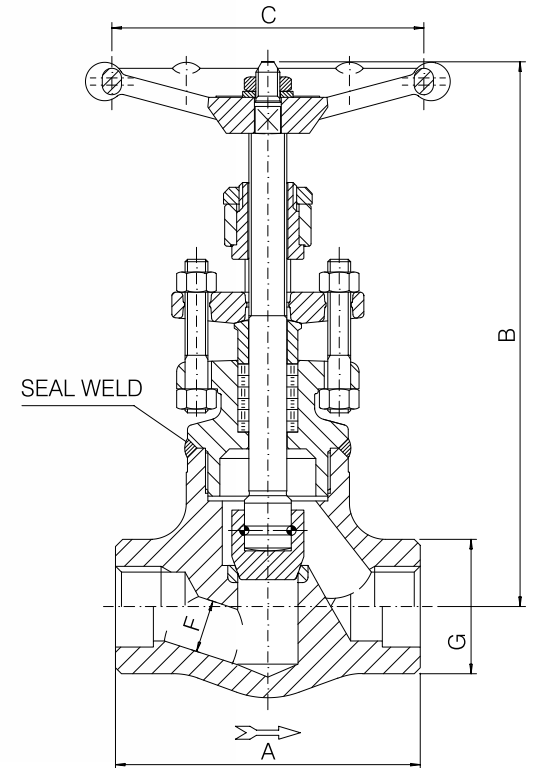

1500 LB.						
FULL PORT - FIG. 9HR 30						
SIZE	inch	1/2	3/4	1	1 1/2	2
	mm	15	20	25	40	50
A	inch	4.33	5.91	5.91	8.27	9.06
	mm	110	150	150	210	230
B open	inch	9.53	12.20	12.20	14.57	18.31
	mm	242	310	310	370	465
C	inch	5.43	5.43	5.43	6.77	9.21
	mm	138	138	138	172	234
F	inch	.47	.59	.75	1.26	1.57
	mm	12	15	19	32	40
G	inch	1.5	2.17	2.17	2.95	3.74
	mm	38	55	55	75	95
Weight	lb.	11	22	22	46.25	79.25
	kg	5	10	10	21	36
PACKING		2B3	2B4	2B4	2B5	2B8
GASKET		R12	R17	R17	R20	R24

2500 LB.						
FULL PORT - FIG. 25HR 30						
SIZE	inch	1/2	3/4	1	1 1/2	2
	mm	15	20	25	40	50
A	inch	5.91	5.91	8.27	9.06	9.06
	mm	150	150	210	230	230
B open	inch	11.97	11.97	14.25	17.17	17.17
	mm	304	304	362	436	436
C	inch	5.43	5.43	5.43	9.21	9.21
	mm	138	138	138	234	234
F	inch	.43	.57	.75	1.10	1.5
	mm	11	14.5	19	28	38
G	inch	2.17	2.17	2.95	3.74	3.74
	mm	55	55	75	95	95
Weight	lb.	22	22	48.5	83.75	83.75
	kg	10	10	22	38	38
PACKING		2B4	2B4	BH8	2B8	4B8
GASKET		R16	R16	R17	R20	R20

800 LB.									
FULL PORT - FIG. W 30									
SIZE	inch	1/4	3/8	1/2	3/4	1	1 1/4	1 1/2	2
	mm	6	10	15	20	25	32	40	50
A	inch	3.15	3.15	3.54	4.33	5	5.91	7.09	8.27
	mm	80	80	90	110	127	150	180	210
B open	inch	6.54	6.54	6.73	8.39	9.72	10.12	11.81	14.76
	mm	166	166	171	213	247	258	300	375
C	inch	3.46	3.46	3.46	3.82	5.43	5.43	6.77	6.77
	mm	88	88	88	97	138	138	172	172
F	inch	.28	.35	.51	.69	.89	1.16	1.38	1.77
	mm	7	9	13	17.5	22.5	29.5	35	45
G	inch	1.26	1.26	1.5	1.89	2.20	2.52	3.07	3.35
	mm	32	32	38	48	56	64	78	85
Weight	lb.	3.75	3.75	4.25	6.5	11	14.75	24.25	36.25
	kg	1.7	1.8	2	3	5	6.8	11	16.5
PACKING		BH3	BH3	BH3	BH5	BY5	BY5	BY7	BH8

800 LB.						
STANDARD PORT - FIG. WL 30						
SIZE	inch	1/2	3/4	1	1 1/2	2
	mm	15	20	25	40	50
A	inch	3.15	3.54	4.33	5.91	7.09
	mm	80	90	110	150	180
B open	inch	6.54	6.73	8.39	10.12	11.81
	mm	166	171	213	258	300
C	inch	3.46	3.46	3.82	5.43	6.77
	mm	88	88	97	138	172
F	inch	.35	.51	.69	1.16	1.38
	mm	9	13	17.5	29.5	35
G	inch	1.26	1.5	1.89	2.52	3.07
	mm	32	38	48	64	78
Weight	lb.	3.75	4.25	6.5	14.5	22.75
	kg	1.7	2	3	6.6	10.4
PACKING		BH3	BH3	BH5	BY5	BY7

1500 LB.									
FULL PORT - FIG. 9W 30									
SIZE	inch	1/4	3/8	1/2	3/4	1	1 1/4	1 1/2	2
	mm	6	10	15	20	25	32	40	50
A	inch	3.54	3.54	4.33	5	5.91	7.09	8.27	9.06
	mm	90	90	110	127	150	180	210	230
B open	inch	6.54	6.54	8.27	9.72	10.08	11.81	14.76	16.85
	mm	166	166	210	247	256	300	375	428
C	inch	3.46	3.46	3.82	5.43	5.43	6.77	6.77	9.21
	mm	88	88	97	138	138	172	172	234
F	inch	.28	.35	.47	.59	.79	1.06	1.26	1.57
	mm	7	9	12	15	20	27	32	40
G	inch	1.5	1.5	1.89	2.20	2.52	3.07	3.35	3.74
	mm	38	38	48	56	64	78	85	95
Weight	lb.	4.75	4.75	7.75	12	16.75	22	44	66
	kg	2.2	2.2	3.5	5.5	7.6	10	20	30
PACKING		BH3	BH3	BH5	2B4	2B4	2B5	BH8	2B8

1500 LB.						
STANDARD PORT - FIG. 9WL 30						
SIZE	inch	1/2	3/4	1	1 1/2	2
	mm	15	20	25	40	50
A	inch	3.54	4.33	5	7.09	8.27
	mm	90	110	127	180	210
B open	inch	6.54	8.27	9.72	11.81	14.76
	mm	166	210	247	300	375
C	inch	3.46	3.82	5.43	6.77	6.77
	mm	88	97	138	172	172
F	inch	.35	.47	.59	1.06	1.26
	mm	9	12	15	27	32
G	inch	1.5	1.89	2.20	3.07	3.35
	mm	38	48	56	78	85
Weight	lb.	4.25	7.75	12	26.25	41.75
	kg	2	3.5	5.5	12	19
PACKING		BH3	BH5	2B4	2B5	BH8

Materials and trim specifications Page 91

# B<sup>®</sup> GLOBE VALVES- WELDED BONNET- FULL PORT

BONNEY FORGE

**2500 LTD.**

**4500 LTD.**

**Design construction:**

- ASME B16.34 Limited Class
- Testing according to API 598
- Marking MSS SP25
- Outside Screw and Yoke (OS&Y)
- Self aligning two piece packing gland
- Integral backseat
- Body bonnet weld to ASME IX
- Loose solid disc
- Socket Weld Ends to ASME B16.11
- Screwed Ends (NPT) to ASME B1.20.1
- Butt Welding Ends to ASME B16.25
- Ratings standard class:
- carbon steel class 2500 6250 psig @ 100°F  
431 bar + 38°C
- carbon steel class 4500 11250 psig @ 100°F  
776 bar + 38°C

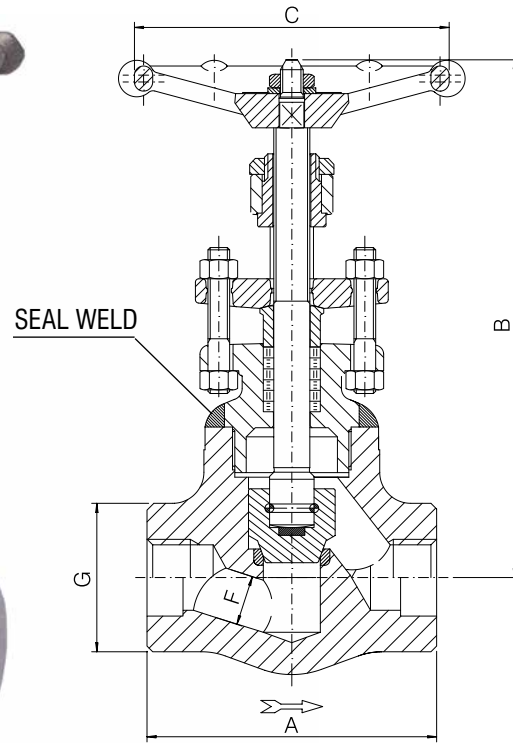

# B<sup>®</sup> GLOBE VALVES- WELDED BONNET- FULL PORT (Y TYPE)

BONNEY FORGE

**800 LTD.**

**1690 LTD.**

**Design construction:**

- ASME B16.34 Limited Class
- Testing according to API 598
- Marking MSS SP25
- Outside Screw and Yoke (OS&Y)
- Self aligning two piece packing gland
- Integral backseat
- Body bonnet weld to ASME IX
- Loose solid disc
- Socket Weld Ends to ASME B16.11
- Screwed Ends (NPT) to ASME B1.20.1
- Butt Welding Ends to ASME B16.25
- Ratings:
- carbon steel class 800 2000 psig @ 100°F  
138 bar + 38°C
- carbon steel class 1690 4225 psig @ 100°F  
291 bar + 38°C

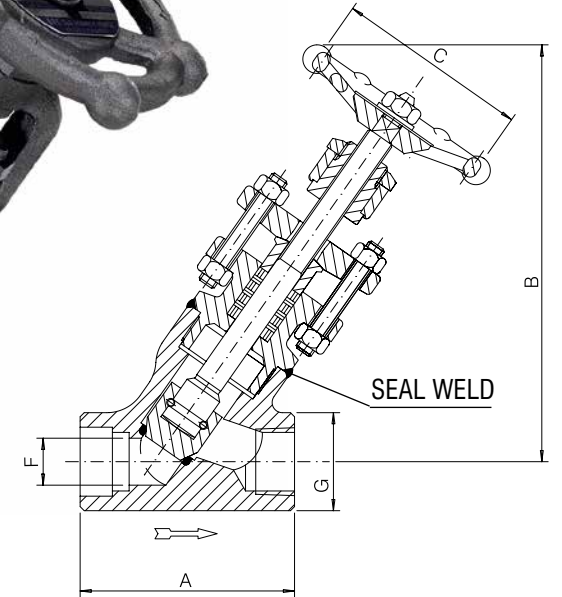

		FULL PORT – FIG. 25W 30								
SIZE	inch mm	1/4 6	3/8 10	1/2 15	3/4 20	1 25	1 1/4 32	1 1/2 40	2 50	
A	inch mm	4.33 110	4.33 110	5 127	5.91 150	7.09 180	7.09 180	8.27 210	9.06 230	
B open	inch mm	7.48 190	7.48 190	8.9 226	9.72 247	11.34 288	11.34 288	14.17 360	16.54 420	
C	inch mm	3.46 88	3.46 88	5.43 138	5.43 138	5.43 138	5.43 138	6.77 172	9.21 234	
F	inch mm	.28 7	.35 9	.43 11	.57 14.5	.75 19	.87 22	1.10 28	1.38 35	
G	inch mm	1.89 48	1.89 48	2.20 56	2.52 64	3.07 78	3.07 78	3.35 85	3.74 95	
Weight	lb. kg	9.75 4.5	10.25 4.7	12 5.5	17.5 8	28.5 13	28.5 13	43.5 19.8	66 30	
PACKING		BH4	BH4	2B3	2B4	2B5	2B5	2B5	2B8	

		FULL PORT – FIG. 45W 30								
SIZE	inch mm	1/4 6	3/8 10	1/2 15	3/4 20	1 25	1 1/4 32	1 1/2 40	2 50	
A	inch mm	5 127	5 127	5 127	7.09 180	7.09 180	9.06 230	9.06 230		
B open	inch mm	9.06 230	9.06 230	9.25 235	11.81 300	11.81 300	14.57 370	15.75 400		
C	inch mm	5.43 138	5.43 138	5.43 138	6.77 172	6.77 172	9.21 234	15.75 400		
F	inch mm	.28 7	.28 7	.31 8	.43 11	.55 14	.98 25	1.26 32		
G	inch mm	2.20 56	2.20 56	2.20 56	3.07 78	3.07 78	3.74 95	4.72 120		
Weight	lb. kg	14.25 6.5	14.25 6.5	14.25 6.5	33 15	33 15	55 25	66 30		
PACKING		2B3	2B3	2B3	4B5	4B5	2B8	4B8		

Available with Socket Weld or Butt-Weld Ends only.  
Materials and trim specifications Page 91

		FULL PORT – FIG. Y 30								
SIZE	inch mm	1/4 6	3/8 10	1/2 15	3/4 20	1 25	1 1/4 32	1 1/2 40	2 50	
A	inch mm	3.35 85	3.35 85	3.35 85	4.13 105	4.72 120	6.5 165	6.5 165	7.48 190	
B open	inch mm	6.85 174	6.85 174	6.85 174	8.46 215	10.04 255	10.04 255	12.52 318	14.76 375	
C	inch mm	3.46 88	3.46 88	3.46 88	3.82 97	5.43 138	6.77 172	6.77 172	6.77 172	
F	inch mm	.28 7	.35 9	.51 13	.69 17.5	.89 22.5	1.38 35	1.38 35	1.77 45	
G	inch mm	1.5 38	1.5 38	1.5 38	1.89 48	2.20 56	3.07 78	3.07 78	3.35 85	
Weight	lb. kg	4.25 2	4.25 2	4.25 2	7.25 3.3	11 5	24.25 11	24.25 11	33 15	
PACKING		BH3	BH3	BH3	BH5	BY5	BY7	BY7	BH8	

		FULL PORT – FIG. 1690Y 30								
SIZE	inch mm	1/4 6	3/8 10	1/2 15	3/4 20	1 25	1 1/4 32	1 1/2 40	2 50	
A	inch mm	3.35 85	3.35 85	4.13 105	4.72 120	6.5 165	6.5 165	7.48 190	8.66 220	
B open	inch mm	6.89 175	6.89 175	8.46 215	10.04 255	11.02 280	12.40 315	14.96 380	17.72 450	
C	inch mm	3.46 88	3.46 88	3.82 97	5.43 138	5.43 138	6.77 172	6.77 172	9.21 234	
F	inch mm	.28 7	.35 9	.47 12	.59 15	.79 20	1.06 27	1.26 32	1.57 40	
G	inch mm	1.5 38	1.5 38	1.89 48	2.20 56	3.07 78	3.07 78	3.35 85	3.74 95	
Weight	lb. kg	4.25 2	4.25 2	7.75 3.5	11.5 5.3	24.25 11	24.25 11	36.25 16.5	57.25 26	
PACKING		BH3	BH3	BH5	2B4	2B4	BY7	BH8	2B8	

Materials and trim specifications Page 91

# GLOBE VALVES- WELDED BONNET- FULL PORT (Y TYPE)

BONNEY FORGE

**2680 LTD.**

**4500 LTD.**

**Design construction:**  
 ASME B16.34 Limited Class  
 Testing according to API 598  
 Marking MSS SP25  
 Outside Screw and Yoke (OS&Y)  
 Self aligning two piece packing gland  
 Integral backseat  
 Body bonnet weld to ASME IX  
 Loose solid disc  
 Socket Weld Ends to ASME B16.11  
 Screwed Ends (NPT) to ASME B1.20.1  
 Butt Welding Ends to ASME B16.25

**Ratings:**  
 - carbon steel class 2680 6700 psig @ 100°F  
 462 bar + 38°C  
 - carbon steel class 4500 11250 psig @ 100°F  
 776 bar + 38°C

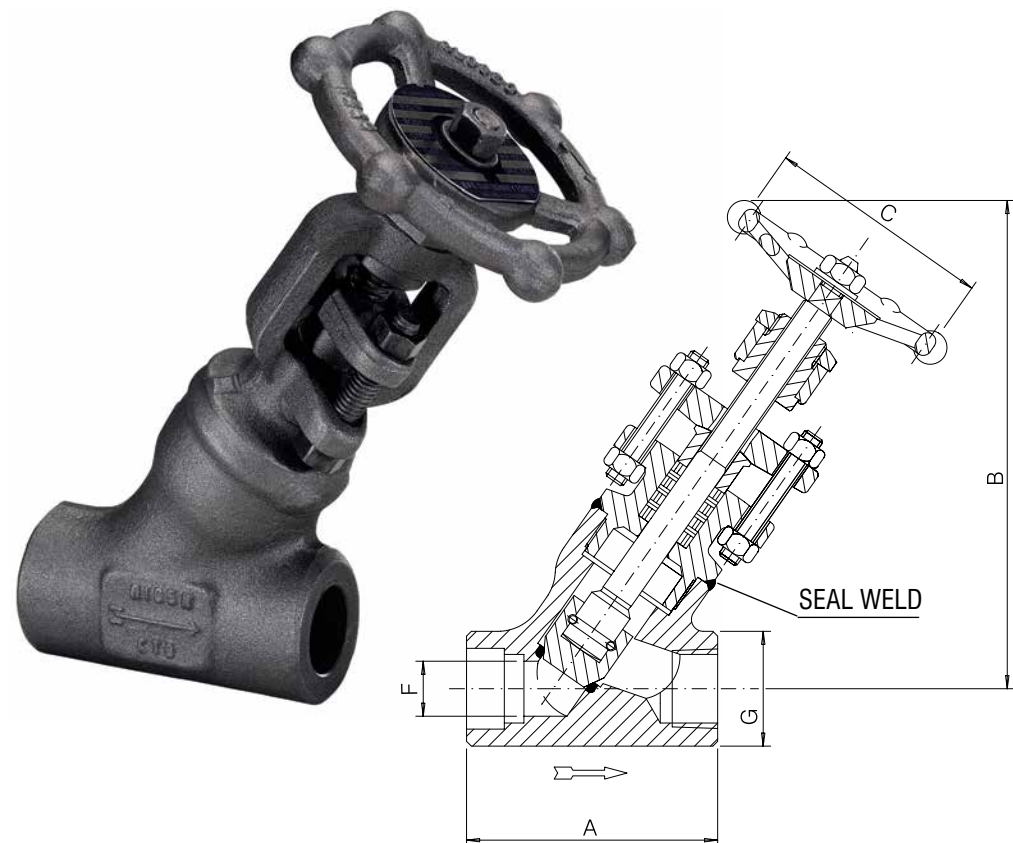

		FULL PORT – FIG. 2680Y 30							
SIZE	inch	1/4	3/8	1/2	3/4	1	1 1/2	2	
	mm	6	10	15	20	25	40	50	
A	inch mm	4.13 105	4.13 105	4.72 120	6.5 165	6.5 165	7.48 190	8.66 220	
B open	inch mm	8.66 220	8.66 220	9.45 240	10.83 275	12.20 310	14.17 360	17.32 440	
C	inch mm	3.46 88	3.46 88	5.43 138	5.43 138	5.43 138	6.77 172	9.21 234	
F	inch mm	.28 7	.35 9	.43 11	.57 14.5	.75 19	1.10 28	1.38 35	
G	inch mm	1.89 48	1.89 48	2.20 56	3.07 78	3.07 78	3.35 85	3.74 95	
Weight	lb.	7.75	7.75	11	25.25	27.5	37.25	67	
	kg	3.5	3.5	5	11.5	12.5	17	30	
PACKING		BH4	BH4	2B3	2B4	2B5	2B5	2B8	

Note: Thread End Valves are limited to ASME B16.34, 2500 Pressure Class.

		FULL PORT – FIG. 45Y 30							
SIZE	inch	1/4	3/8	1/2	3/4	1	1 1/2	2	
	mm	6	10	15	20	25	40	50	
A	inch mm	4.72 120	4.72 120	4.72 120	6.5 165	6.5 165	8.66 220	9.06 230	
B open	inch mm	9.45 240	9.45 240	9.65 245	12.01 305	12.20 310	16.54 420	17.72 450	
C	inch mm	5.43 138	5.43 138	5.43 138	6.77 172	6.77 172	9.21 234	15.75 400	
F	inch mm	.28 7	.28 7	.31 8	.43 11	.55 14	.98 25	1.26 32	
G	inch mm	2.20 56	2.20 56	2.20 56	3.07 78	3.07 78	3.74 95	4.72 120	
Weight	lb.	12	12	12.25	30.75	30.75	61.75	70.5	
	kg	5.5	5.5	5.6	14	14	28	32	
PACKING		2B3	2B3	2B3	2B4A	4B5	2B8	4B8	

Available with Socket Weld or Butt-Weld Ends only.  
 Materials and trim specifications Page 91

Overview .....24

Bolted Bonnet- 800 lb. & 1500 lb. valves .....25

Bolted Bonnet- 1500 lb. & 2500 lb. valves .....26

Welded Bonnet- 800 lb. & 1500 lb. valves .....27

Welded Bonnet- 2500 lb. & 4500 lb. valves .....28

Welded Bonnet (Y type)- 800 lb. & 1690 lb. valves .....29

Welded Bonnet (Y type)- 2680 lb. & 4500 lb. valves .....30

## CHECK VALVES

